



CROWN-PT\_Man.Drills\_01.2023\_V.1.3\_ASIA-02

# CROWN

TOOLS FOR A BETTER LIFE

- CT10125
- CT10143
- CT10143C
- CT10127
- CT10127C
- CT10127-13
- CT10127-13C
- CT10179
- CT10179C

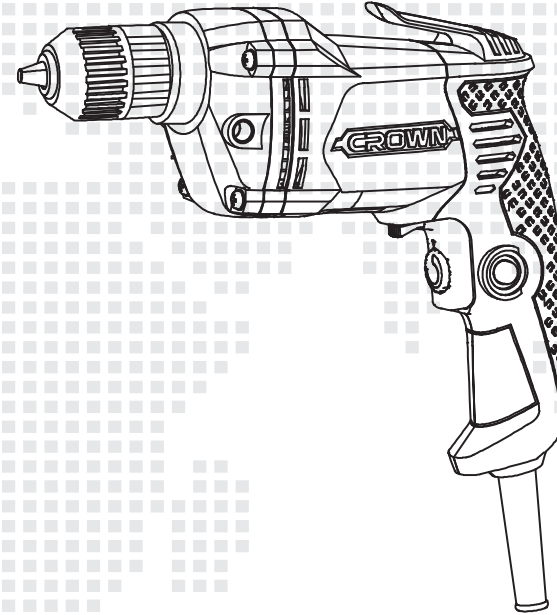

Shanghai Merit Link Hardware & Tools Co., Ltd.  
138 Jiangchang 3rd road, 4th floor, Shanghai

上海脉链五金工具有限公司  
上海市江场三路138号4楼



En Instruction manual  
中文 说明书

Read and understand the manual before using the machine.  
操作前，请务必认真阅读使用说明书

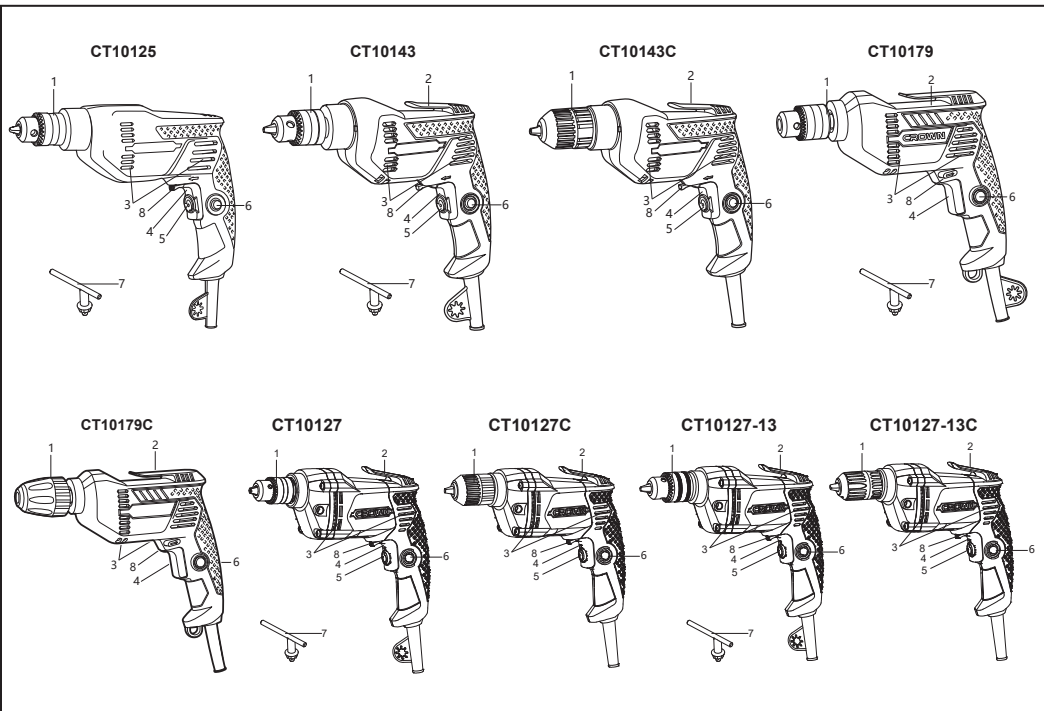

CT10127, CT10127C, CT10127-13, CT10127-13C,

1

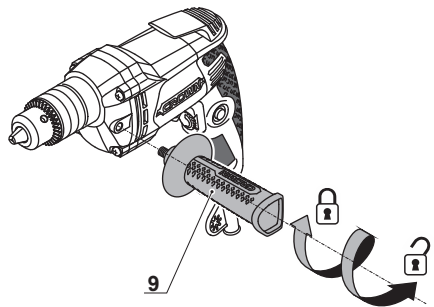

CT10125 / CT10126 / CT10127 / CT10127-13 / CT10143 / CT10143-13/CT10179

2

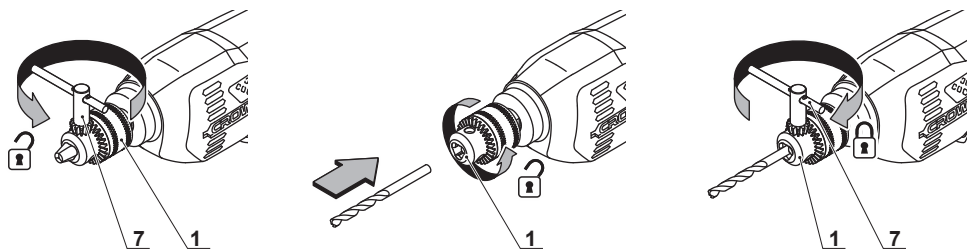

1

CT10127C/CT10143C/CT10179C

3

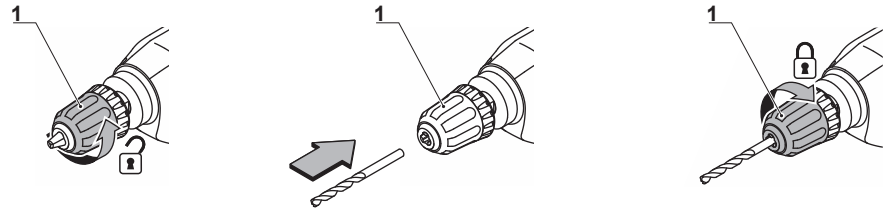

CT10127-13C

4

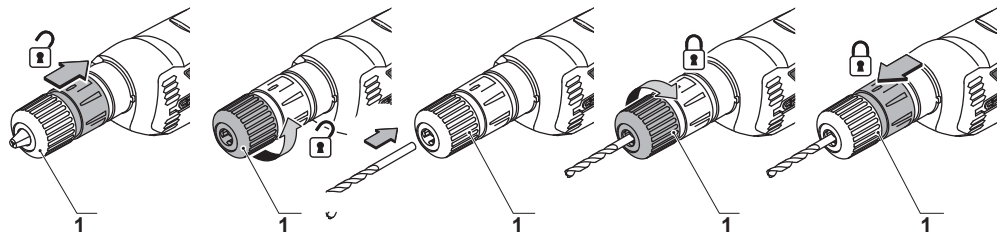

CT10125/CT10143/CT10127/CT10127-13/CT10179

5

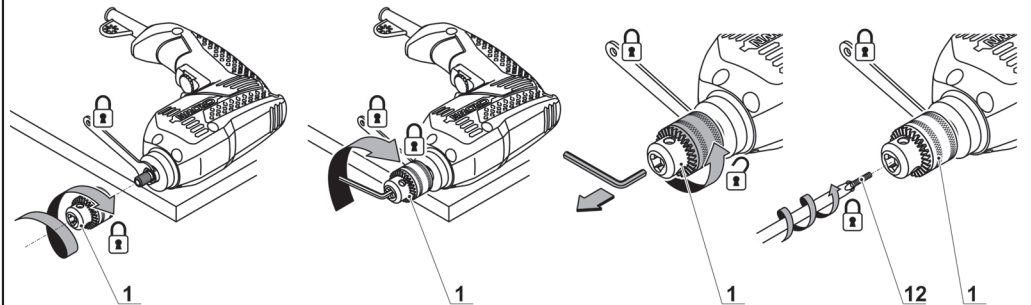

CT10127C/CT10127-13C/CT10143C/CT10179C

6

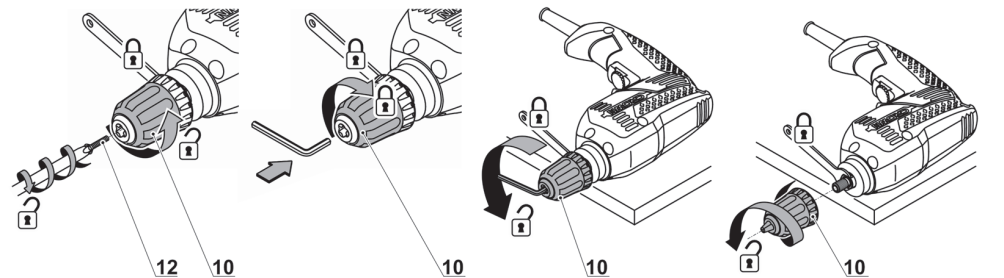

2

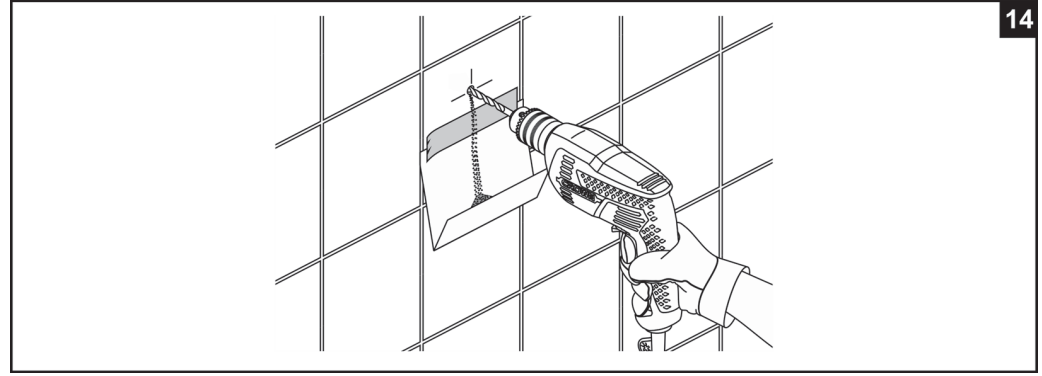
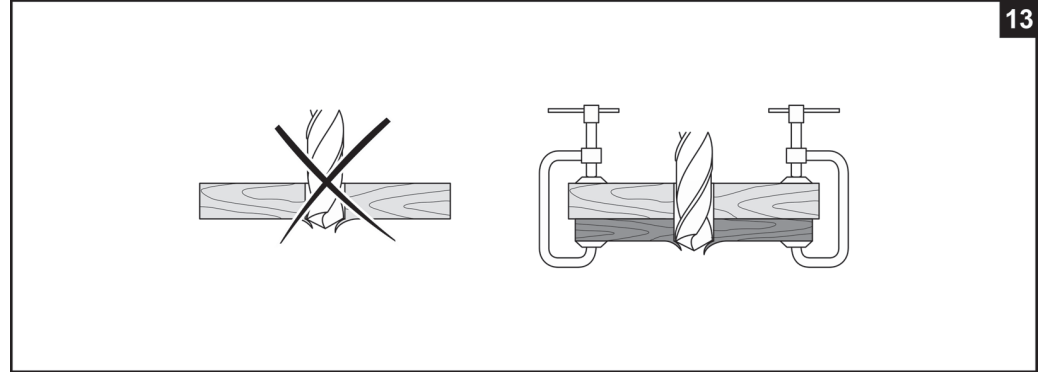
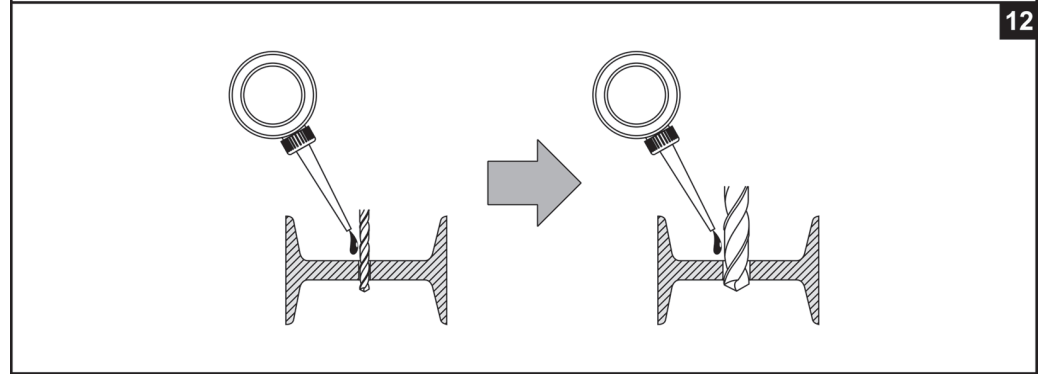
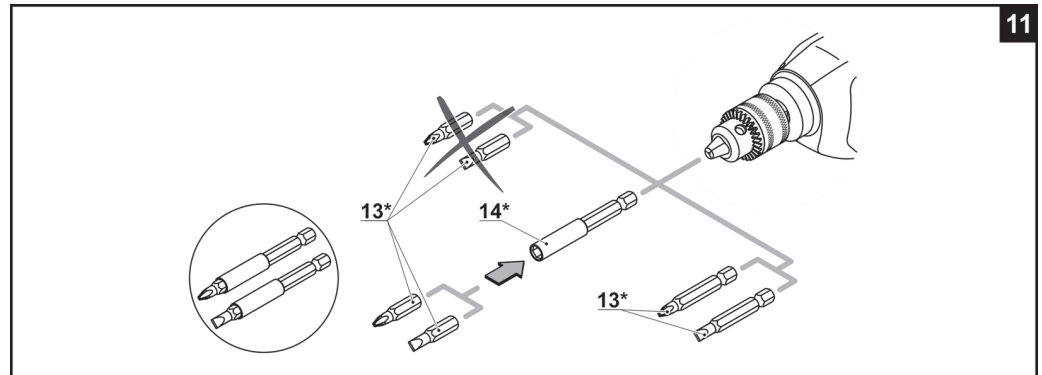
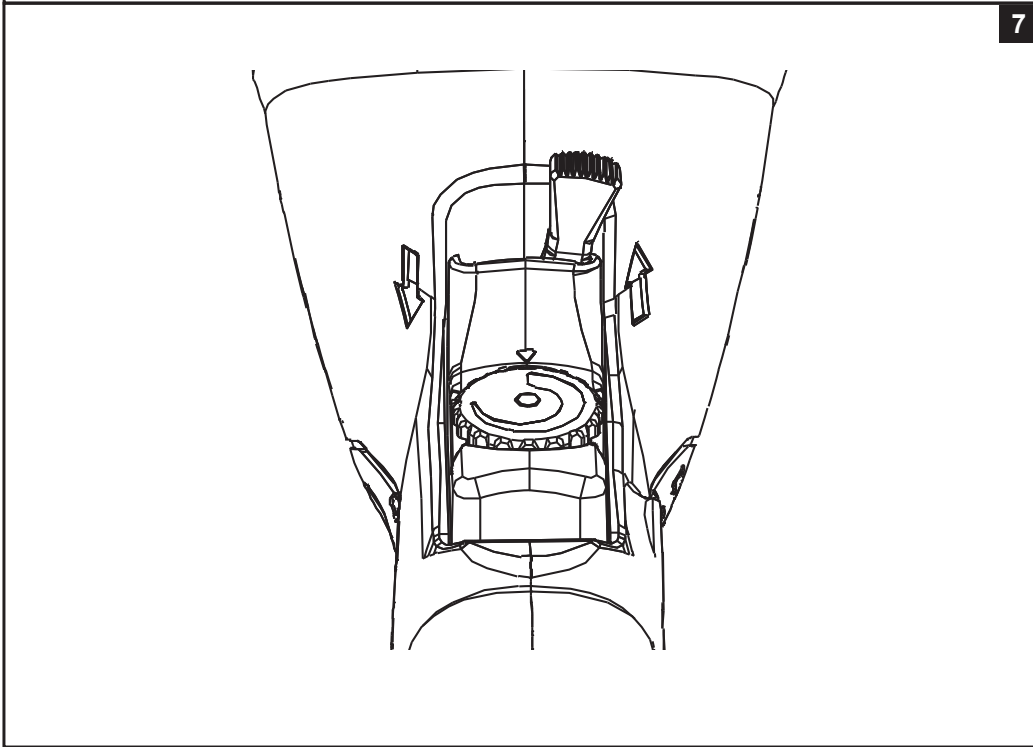
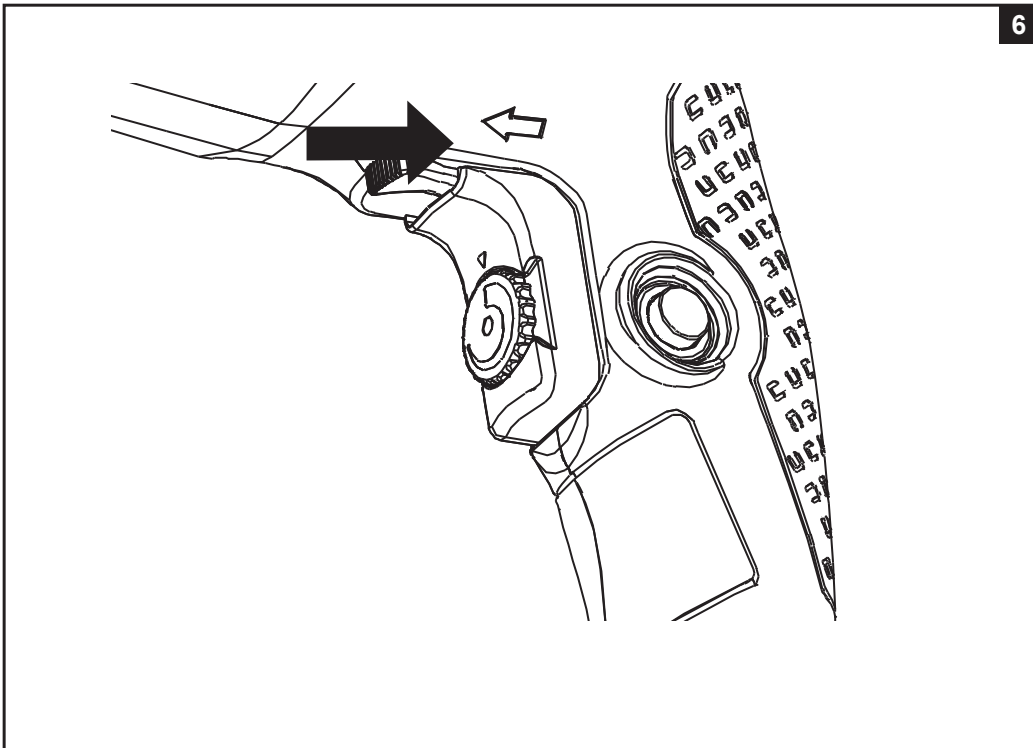



**WARNING – To reduce the risk of injury, user must read instruction manual!**

## I. General Safety Rules



**WARNING!** Read all safety warnings and all instructions. Failure to follow the warnings and instructions may result in electric shock, fire and/or serious injury.

Save all warnings and instructions for future reference.

The term "power tool" in the warnings refers to your mains-operated (corded) power tool or battery-operated (cordless) power tool.

### 1) Work area safety

- a) **Keep work area clean and well lit.** Cluttered or dark areas invite accidents.
- b) **Do not operate power tools in explosive atmospheres, such as in the presence of flammable liquids, gases or dust.** Power tools create sparks which may ignite the dust or fumes.
- c) **Keep children and bystanders away while operating a power tool.** Distractions can cause you to lose control.

### 2) Electrical safety

- a) **Power tool plugs must match the outlet. Never modify the plug in any way. Do not use any adapter plugs with earthed (grounded) power tools.** Unmodified plugs and matching outlets will reduce risk of electric shock.
- b) **Avoid body contact with earthed or grounded surfaces, such as pipes, radiators, ranges and refrigerators.** There is an increased risk of electric shock if your body is earthed or grounded.
- c) **Do not expose power tools to rain or wet conditions.** Water entering a power tool will increase the risk of electric shock.
- d) **Do not abuse the cord. Never use the cord for carrying, pulling or unplugging the power tool. Keep cord away from heat, oil, sharp edges or moving parts.** Damaged or entangled cords increase the risk of electric shock.

e) **When operating a power tool outdoors, use an extension cord suitable for outdoor use.** Use of a cord suitable for outdoor use reduces the risk of electric shock.

f) **If operating a power tool in a damp location is unavoidable, use a residual current device (RCD) protected supply.** Use of an RCD reduces the risk of electric shock. NOTE The term "residual current device (RCD)" may be replaced by the term "ground fault circuit interrupter (GFCI)" or "earth leakage circuit breaker (ELCB)".

### 3) Personal safety

- a) **Stay alert, watch what you are doing and use common sense when operating a power tool. Do not use a power tool while you are tired or under the influence of drugs, alcohol or medication.** A moment of inattention while operating power tools may result in serious personal injury.
- b) **Use personal protective equipment. Always wear eye protection.** Protective equipment such as dust mask, non-skid safety shoes, hard hat, or hearing protection used for appropriate conditions will reduce personal injuries.
- c) **Prevent unintentional starting. Ensure the switch is in the off-position before connecting to power source and/or battery pack, picking up or carrying the tool.** Carrying power tools with your finger on the switch or energising power tools that have the switch on invites accidents.
- d) **Remove any adjusting key or wrench before turning the power tool on.** A wrench or a key left attached to a rotating part of the power tool may result in personal injury.
- e) **Do not overreach. Keep proper footing and balance at all times.** This enables better control of the power tool in unexpected situations.
- f) **Dress properly. Do not wear loose clothing or jewellery. Keep your hair, clothing and gloves away from moving parts.** Loose clothes, jewellery or long hair can be caught in moving parts.
- g) **If devices are provided for the connection of dust extraction and collection facilities, ensure these are connected and properly used.** Use of dust collection can reduce dust-related hazards.
- h) **Do not let familiarity gained from frequent use of tools allow you to become complacent and ignore tool safety principles.** A careless action can cause severe injury within a fraction of a second.
- i) **Do not be discreet and ignore the safety guidelines of the tools because of the familiarity of using tools frequently.** A careless movement may cause serious injuries in an instant.

### 4) Power tool use and care

a) **Do not force the power tool. Use the correct power tool for your application.** The correct power tool will do the job better and safer at the rate for which it was designed.

- b) **Do not use the power tool if the switch does not turn it on and off.** Any power tool that cannot be controlled with the switch is dangerous and must be repaired.
- c) **Disconnect the plug from the power source and/or the battery pack from the power tool before making any adjustments, changing accessories, or storing power tools.** Such preventive safety measures reduce the risk of starting the power tool accidentally.
- d) **Store idle power tools out of the reach of children and do not allow persons unfamiliar with the power tool or these instructions to operate the power tool.** Power tools are dangerous in the hands of untrained users.
- e) **Maintain power tools. Check for misalignment or binding of moving parts, breakage of parts and any other condition that may affect the power tool's operation. If damaged, have the power tool repaired before use.** Many accidents are caused by poorly maintained power tools.
- f) **Keep cutting tools sharp and clean.** Properly maintained cutting tools with sharp cutting edges are less likely to bind and are easier to control.
- g) **Use the power tool, accessories and tool bits etc. in accordance with these instructions, taking into account the working conditions and the work to be performed.** Use of the power tool for operations different from those intended could result in a hazardous situation.
- h) **Keep handles and grasping surfaces dry, clean and free from oil and grease.** Slippery handles and grasping surfaces do not allow for safe handling and control of the tool in unexpected situations.
- i) **Keep the handle and holding surface dry and clean.** In an accidental situation, a slippery handle does not guarantee the security of the grip and the control of the tool.

### 5) Service

**Have your power tool serviced by a qualified repair person using only identical replacement parts.** This will ensure that the safety of the power tool is maintained.

## II. Special Safety Warnings

### Electric drill safety warning

– **Earmuffs for impact operations. Exposure to noise can lead to deafness.**

This warning applies only to impact drills, which can be omitted for drills.

- **Use the auxiliary handle. Loss of control can lead to personal injury.**

This warning only applies to tools with auxiliary handles.

- **The tool should be properly supported before use. Due to the large output torque of the tool, no proper support during operation will result in loss of control and personal injury.**

This warning only applies to tools with a maximum output torque exceeding 100 Nm measuring with 19.101.

- **When working with a drilling attachment that may touch the dark line or its own wire, hold the tool through the insulated holding surface. Drilling accessories that come into contact with live conductors can electrify the exposed metal parts of the tool and subject the operator to electric shocks.**

- **For the stirrer, do not open and close the tool unless the stirrer is in the mixing material.** Failure to do so can result in loss of control and personal injury.

### Additional safety requirements

1. The workpiece shall be fastened. Fixed devices or vice shall be used to fasten the workpiece, which will be more secure than holding the workpiece with your hands.
2. Considering that asbestos may cause cancer, asbestos-containing materials shall not be processed.
3. The machine could be put down only after the electric tool is completely static. Tools on the machine might be clamped during work, which may make it difficult for you to control the electric tool.
4. Electric tools with damaged electric wires shall not be used. If electric wires of the power supply are damaged during the work, you shall not touch the damaged electric wires and shall pull out the plug immediately. Damaged electric wires will raise the risk of electric shock.
5. When using electric tools outdoor, you must install fault current (FI) protection switch on the electric tools.
6. Appropriate detector shall be used to find the location of hidden power wires. Or you should obtain relevant information from local power supply unit. Drilling electric wires will cause fire and electric shock. Damaged gas pipe will cause explosion. If water pipes are punctured, damage will be caused to property.
7. In case a tool installed on the machine is clamped, you shall shut down the electric tool and stay calm. At that time, the machine will produce extremely high reactive torque thus resulting in return stroke. The tools installed on the machine are likely to be clamped, for example: hypercharge of electric tool or skewing of tools installed on the machine during work.

8. If hidden electric wires or power lines of the machine itself might be cut off during work, you must hold the insulated handle to operate the machine. When the electric tool is in touch with a charged line, the metal parts on the machine will conduct electricity and may cause the operator to get an electric shock.
9. During work, you must tightly hold the electric tool and ensure you stand firmly. You should hold the electric tool with your hands.
10. When operating and using the tool, you can only hold switch position of the main handle rather than other parts.

### Features and usage

This product is based on single phase series motor as the driving force and has single function of rotation only. It is applicable to drilling on metal, wood, plastics and other materials. It has switch stroke speed regulation and positive / reverse functions and could also loosen/tighten the screws and tap. It has high speed of drilling and high drilling precision. It could improve installation speed and quality of various pipelines (such as water, electricity and gas), machine tool and equipment. The construction cost is low.

### Signs



Read the manual



Wear goggles



Wear earmuffs



Wear a dust mask please



Sign of double insulation for Grade II tools



Material recycling in lieu of waste disposal. Detailed classification shall be made for recycling in response to environmental protection, machine and fittings or packaged damaged. This manual is printed with chlorine-free recycled paper. For the plastic parts, detailed composition of such plastics is also indicated.

### III. Major parameters

1. Drill Chuck
2. Belt buckle
3. Vent
4. Switch trigger
5. Speed control knob
6. Switch locking button
7. Chuck key
8. Rotational direction switch
9. handle



In order to reduce the impact of electromagnetic interference generated by the tool on the human body and avoid possible risks when cutting accessories may touch the dark wire or its own flexible wire, the tool must be held by insulated holding surface.

Model	CT10125	CT10143	CT10143C	CT10127	CT10127C	CT10127-13	CT10127-13C	CT10179	CT10179C
Rated power (W)	300	500	500	750	750	750	750	500	500
Output power (W)	130	280	280	392	392	392	392	275	275
Rated voltage (V)	220-230	220-230	220-230	220-230	220-230	220-230	220-230	220-230	220-230
Frequency (Hz)	50/60	50/60	50/60	50/60	50/60	50/60	50/60	50/60	50/60
Amperage at 220-230V (A)	1.35	2.4	2.4	3.5	3.5	3.5	3.5	2.4	2.4
No-load speed (r/min)	0-3800	0-2800	0-2800	0-3000	0-3000	0-3000	0-3000	0-3200	0-3200
Security level	□/	□/	□/	□/	□/	□/	□/	□/	□/
Security level (kg)	1	1.38	1.4	1.58	1.65	1.69	1.7	1.26	1.26
Variable speed	Yes	Yes	Yes	Yes	Yes	Yes	Yes	Yes	Yes
Chuck type	Gear rim chuck	Gear rim chuck	keyless chuck	Gear rim chuck	keyless chuck	Gear rim chuck	keyless chuck	Gear rim chuck	keyless chuck
Clamping range (mm)	0.5-6.5	1.5-10	0.8-10	1.5-10	0.8-10	1.5-13	2-13	1-10	0.8-10
Drill spindle connecting thread	3/8"-24UNF	3/8"-24UNF	3/8"-24UNF	3/8"-24UNF	3/8"-24UNF	1/2"-20UNF	1/2"-20UNF	3/8"-24UNF	3/8"-24UNF
Drilling	steel (mm)	6.5	10	10	10	13	13	10	10
	wood (mm)	13	25	25	32	32	32	25	25

## IV. Functional operating instructions



**Warning! Before the maintenance of electric tool or the replacement of parts and accessories, the plug must be pulled out of the socket.**

### Install side handles

Confirm that side handles have been securely fitted before operation. Screw up side handles to the required position of the tool as shown in the figure 1.

### Installation and disassembly of drill

1. Rotate the key anticlockwise, to unscrew the chuck, assemble the drill into the three holes of the chuck, and screw the chuck by rotating it clockwise. Disassemble the drill, rotate the chuck anticlockwise, and then take out the drill. (Figure 2)
2. Hold the lantern ring and rotate the sleeve anticlockwise to open the chuck, assemble the drill into the chuck, hold the lantern ring tightly and rotate the sleeve clockwise to tighten the chuck. For the disassembly of the drill, please hold the lantern ring and rotate the sleeve anticlockwise. (Figure 3)

### Switch

1. Open and close (Figure 5)

Slowly press the switch trigger of the tool, then the tool starts to operate from slowly to fast; completely press down the trigger, and the tool will operate at the maximum speed. Completely release the trigger, then the tool will be under off state. If the switch is locked, press the self-locking button when buckling up the trigger. The tool will operate continuously; Re-press the trigger to completely release it, i.e., the tool is under off state.

2. Forward and reverse switch (Figure 6)

Hold the tool, turn the lifting lever to “ $\leftarrow$ ” is forward; Turn to “ $\rightarrow$ ” is reversal

Remember: The change of rotating direction of tool shall be conducted after the drill is completely stopped.

Belt buckle. The electric drill can be hung on the belt with belt buckle clip, therefore the hands can be set free and the tools can be at the fingertips.

1. Use specified voltage, and the voltage of circuit shall not exceed the voltage specified on the electric drill nameplate plus or minus 5%.
2. Inspection before use, make the tool idle for one minute before use, to check whether the drive is flexible, whether there is abnormal noise and whether the spark is normal.

### Effective and safe operation methods

1. Drilling. For the drilling of metal workpieces with larger thickness or of harder materials, suitable coolant shall be applied, otherwise, the service life of the drill will be reduced.
2. Tightening and disassembly of bolt. They can be achieved with screwdriver and connecting rod (separately purchased).
3. How to use power switch and function switch. Press the switch down to open and release it to close. When moving on the working surface, the electric drill shall be switched off.

### Operating instructions

1. Use specified voltage, and the voltage of circuit shall not exceed the voltage specified on the electric drill nameplate plus or minus 5%.
2. Inspection before use: Make the tool idle for one minute before use, to check whether the drive is flexible, whether there is abnormal noise and whether the spark is normal.
3. How to use power switch and function switch. Press the switch down to open and release it to close. When moving on the working surface, the electric drill shall be switched off.
4. For the convenience of operation, there is a locking button on the switch of the tool. As shown in Figure 5, stick up the switch trigger in position according to the direction of arrow with right hand, press the locking button on the switch with left hand, and then, release the switch trigger and locking button, i.e., switch locked. For unlocking, simply to stick up the switch trigger.
5. In order to meet the demands of different service conditions, it is able to control the output speed by adjusting the switch speed control knob (5).
6. How to assemble and disassemble drill chuck. For the assembly of drill chuck, wipe clean the inserting part (i.e., output shaft), apply a few grease, align the thread end of output shaft with the mating hole of drill chuck, start the electric drill to slowly rotate clockwise, and hold the drill chuck with left hand until the drill chuck is completely matched with the end face of the output shaft. If the drill is not in position, when drilling, it may shake. Finally, screw one M5\*20 left-hand thread bolt into the chuck with screwdriver and tighten the output shaft.
7. Overload protection. The drill must be sharp. When drilling, do not be too violently. In case of abnormal lowering of rotate speed, reduce the force immediately. In case of the sudden brake or sticking of drill, cut off the power supply immediately.
8. Replacement of electric brush. For electric brush wears to a certain degree, small spring in the carbon brush will operate automatically. Cut off the power supply, stop the electric drill, and then replace the electric brush (two brushes shall be replaced at the same time).
9. It cannot be used under the following conditions. For the damage of insulation, fracture of power line or cable sheath, cracking or poor contact of plug and socket, or serious spark and other faults during the use process, repair must be conducted immediately. And the electric drill cannot be used before recovery. The electric drill shall

be stopped for overheating.

10. Keep the tool clean. The airway of electric drill must be kept clean and unblocked, to avoid the entering of debris. After use, the electric drill shall be repaired immediately to make the electric drill always under clean and good condition.

11. All tools shall be carefully used and handled with care, to avoid shock. Plastic parts shall not contact with gasoline, alcohol, etc. to avoid cracking.

### Convenient tips

1. Drilling
  - a) Guarantee that the materials are firmly clamped before drilling. The fragile sheet shall be supported with backboard, to avoid the workpieces damage when drilling.
  - b) Apply pressure to drill in straight line, make the drill in with proper pressure (avoid overexerting), to avoid motor stall or drill deviation.
  - c) The stall of electric drill may be caused by overload or misuse. Do not switch on and off the trigger switch frequently, to avoid the damage to electric drill.
  - d) In order to reduce the material damage due to stall, reduce the speed and pressure when the hole is going to be drilled out.
  - e) When pulling the drill out from the hole, keep the motor running to prevent the sticking of drill.
  - f) No pre-punching at the drilling position is need for electric drill with speed control function. Start drilling with slow speed and press the trigger switch to raise speed, until the hole is drilled and the drill will not be deflected.
2. Drilling of metal
  - a) Select rotary drilling mode
  - b) Start drilling with slow speed and raise the speed and pressure slowly, then the metal filing will flow out evenly and smoothly, i.e., the speed and pressure of drilling are correct.
  - c) When drilling metal, cutting lubricating oil shall be used; Cast iron and brass are exceptions and shall be drilled at dry drilling. The best cutting lubricating oil is sulfur-containing cutting lubricating oil or lard oil.
  - d) To make the drilling of large hole (8-10mm) easier, a small hole (4-5mm) shall be pre-drilled before drilling.
3. Drilling of timber
  - a) Select rotary drilling mode
  - b) Start drilling with slow speed and raise the speed and pressure slowly.
  - c) Dedicated carpenter drill shall be applied. Pull the drill out of the hole timely and clean the bits of wood on it, to avoid overheating of drill.

## V. Servicing, maintenance and contact information of after-sale services

### Maintenance and cleaning

Before the maintenance and inspection, cut off the power supply and disconnect the plug. Regularly clean the dust, greasy dirt and other bad attachments in the tool body. Maintain the clean and tidy of tools. Check the bolt at all connection parts regularly for loosening, and the outer shell for cracking and damage. Check the insulating layer of power line regularly for damage.

### Regular replacement of carbon brush Add grease

The carbon brush of this tool is built-in type, therefore, its replacement shall be conducted by the maintenance station authorized by the dealer or Merit Link Company. For the occasional sparking or slacking of tool that are in operation, please check carbon brush of the tool and cut off the power supply before check. When replacing the new carbon brush, please replace the lubricating oil which shall be known product.

Parts that can be replaced: Switch, power line, capacitor and carbon brush

**Attention:** The replacement of power line must be conducted by the dealer authorized by Merit Link Company or professional maintenance personnel in customer services

### Disposal of waste

Damaged machine, accessories and discarded package materials must be recycled and reused in an environmentally friendly way.

### Reserves the right of modification

The Company reserves the right of modification of this Introduction.

### After-sales service

Manufacture : Shanghai Merit Link Hardware & Tools Co.,Ltd.

Address: 4F, No.138, Jiangchang 3rd road, Jingan District, Shanghai, China.

Telephone: +86-21-36321892

Fax: +86-21-36321521

4008832658 (china)

www.meritlink.com

Production place: Zhejiang



## 警告 – 为降低受伤害风险, 操作者必须阅读说明书!

### 一、一般安全使用说明

#### 电动工具通用安全警告



**警告!** 阅读随电动工具提供的所有安全警告、说明、图示和规定。不遵照以下所列说明会导致电击、着火和 / 或严重伤害。

保存所有警告和说明书以备查阅。

警告中的术语“电动工具”是指市电驱动(有线)电动工具或电池驱动(无线)电动工具。

#### a) 工作场地的安全

- 1) 保持工作场地清洁和明亮。杂乱和黑暗的场地会引发事故。
- 2) 不要在易爆环境, 如有易燃液体、气体或粉尘的环境下操作电动工具。电动工具产生的火花会点燃粉尘或气体。
- 3) 操作电动工具时, 远离儿童和旁观者。注意力不集中会使你失去对工具的控制。

#### b) 电气安全

- 1) 电动工具插头必须与插座相配。绝不能以任何方式改装插头。需接地的电动工具不能使用任何转换插头。未经改装的插头和相配的插座将降低电击风险。
- 2) 避免人体接触接地表面, 如管道、散热片和冰箱。如果你身体接触接地表面会增加电击风险。
- 3) 不得将电动工具暴露在雨中或潮湿环境中。水进入电动工具将增加电击风险。
- 4) 不得滥用软线。绝不能用软线搬运、拉动电动工具或拔出其插头。使软线远离热源、油、锐边或运动部件。受损或缠绕的软线会增加电击风险。
- 5) 当在户外使用电动工具时, 使用适合户外使用的延长线。适合户外使用的电线将降低电击风险。
- 6) 如果无法避免在潮湿环境中操作电动工具, 应使用带有剩余电流装置(RCD)保护的电源。RCD的使用可降低电击风险。

注: 术语“剩余电流装置(RCD)”可以用“接地故障电路断路器(GFCI)”或“接地泄漏电路断路器(ELCB)”术语代替。

#### c) 人身安全

- 1) 保持警觉, 当操作电动工具时关注所从事的操作并保持清醒。当你感到疲倦, 或在有药物、酒精或治疗反应时, 不要操作电动工具。在操作电动工具时瞬间的疏忽会导致严重人身伤害。
- 2) 使用个人防护装置。始终佩戴护目镜。防护装置, 诸如适当条件下使用防尘面具、防滑安全鞋、安全帽、听力防护等装置能减少人身伤害。
- 3) 防止意外起动。在连接电源和/或电池包、拿起或搬运工具前确保开关处于关断位置。手指放在开关上搬运工具或开关处于接通时通电会导致危险。
- 4) 在电动工具接通之前, 拿掉所有调节钥匙或扳手。遗留在电动工具旋转零件上的扳手或钥匙会导致人身伤害。
- 5) 手不要过分伸展。时刻注意立足点和身体平衡。这样能在意外情况下能更好地控制住电动工具。
- 6) 着装适当。不要穿宽松衣服或佩戴饰品。让你的头发和衣服远离运动部件。宽松衣服、佩饰或长发可能会卷入运动部件。
- 7) 如果提供了与排屑、集尘设备连接用的装置, 要确保他们连接完好且使用得当。使用集尘装置可降低尘屑引起的危险。
- 8) 不要因为频繁使用工具而产生的熟悉感而掉以轻心, 忽视工具的安全准则。某个粗心的动作可能在瞬间导致严重的伤害。

#### d) 电动工具使用和注意事项

- 1) 不要勉强使用电动工具, 根据用途使用合适的电动工具。选用合适的按照额定值设计的电动工具会使你工作更有效、更安全。
- 2) 如果开关不能接通或关断电源, 则不能使用该电动工具。不能通过开关来控制的电动工具是危险的且必须进行修理。
- 3) 在进行任何调节、更换附件或贮存电动工具之前, 必须从电源上拔掉插头和/或卸下电池包(如可拆卸)。这种防护性的安全措施降低了电动工具意外起动的风险。
- 4) 将闲置不用的电动工具贮存在儿童所及范围之外, 并且不允许不熟悉电动工具和不了解这些说明的人操作电动工具。电动工具在未经培训的使用者手中是危险的。
- 5) 维护电动工具及其附件。检查运动部件是否调整到位或卡住, 检查零件破损情况和影响电动工具运行的其他状况。如有损坏, 应在使用前修理好电动工具。许多事故是由维护不良的电动工具引发的。
- 6) 保持切削刀具锋利和清洁。维护良好地有锋利切削刃的刀具不易卡住而且容易控制。
- 7) 按照使用说明书, 并考虑作业条件和要进行的作业来选择电动工具、附件和工具的刀头等。将电动工具用于那些与其用途不符的操作可能会导致危险情况。

8) 保持手柄和握持表面干燥、清洁, 不得沾有油脂。在意外的情况下, 湿滑的手柄不能保证握持的安全和对工具的控制。

#### e) 维修

由专业维修人员使用相同的备件维修电动工具。这将保证所维修的电动工具的安全。

### 二、特殊安全使用说明

#### 电钻安全警告

——带耳罩进行冲击作业。暴露于噪声环境会导致失聪。

该警告仅适用于冲击电钻, 电钻可以省略。

——使用辅助手柄。失控会导致人身伤害。

该警告仅适用于带辅助手柄的工具。

——工具使用前应得到适当支撑。由于工具输出扭矩大, 运行时没有适当支撑会失控导致人身伤害。

该警告仅适用于按照19.101测量得到的最大输出扭矩超过100Nm的工具。

——当在钻削附件可能触及暗线或其自身导线的场合进行操作时, 要通过绝缘握持面握持工具。钻削附件碰到带电导线会使工具外露的金属零件带电而使操作者受到电击。

——对于搅拌机, 除非搅拌装置位于搅拌材料中, 否则不要开启和关闭工具。不这样操作会导致失控而产生人身伤害。

#### 附加安全要求

1. 固定好工件。使用固定装置或老虎钳固定工件, 会比用手持握工件更牢固。

2. 勿加工含石棉的物料。石棉可能致癌。

3. 等待电动工具完全静止后才能够放下机器。机器上的工具可能在工作中被夹住, 而令您无法控制电动工具。

4. 勿使用电线已经损坏的电动工具。如果电源电线在工作中受损, 千万不可触摸损坏的电线, 并马上拔出插头。损坏的电线会提高使用者触电的危险。

5. 在户外使用电动工具时, 必须在电动工具上安装故障电流(FI)保护开关。

6. 使用合适的侦测器, 以便找出隐藏着的电源线的位罝。或者向当地的供电单位索取相关资料。钻穿电线会造成火灾并遭受电击。损坏瓦斯管会引起爆炸。如果水管被刺穿了会导致财物损失。

7. 如果安装在机器上的工具被夹住了, 必须马上关闭电动工具并保持镇静。此时机器会产生极高的反应力矩, 并进而造成回击。安装在机器上的工具容易被夹住, 如: 电动工具超荷了, 或者安装在机器上的工具在工件中歪斜了。

8. 如果工作时可能割断隐藏着的电线或机器本身的电源线, 那么一定要握着绝缘手柄操作机器。电动工具如果接触了带电的线路, 机器上的金属部件会导电, 并可能造成操作者触电。

9. 工作时必须用双手握紧电动工具, 并且要确保立足稳固。使用双手比较能够握稳电动工具。

10. 在操作使用工具时, 只能握持在主手柄开关位置, 其它部位为不可握持部位。

#### 特点及用途

本产品是以单相串激电动机为动力, 只具有旋转单一功能, 适用于金属, 木材, 塑料等材料上钻孔。配备开关行程调速和正/逆转功能, 也能够松/紧螺丝和攻牙。钻孔速度快, 成孔精度高, 可提高各种管道(如水, 电, 煤气), 机床, 设备等安装速度和质量, 低施工费用。它是一切建筑施工, 设备安装部门的理想工具。

### 标志



阅读使用说明书



请佩戴防护眼镜



请佩戴耳罩



请佩戴防尘面罩



二类工具双重绝缘标志



以原料回收代替垃圾处理, 为了响应环保, 机器、配件及包装如损坏, 须详细分类一律回收。本说明书是由不含氯的再生纸张印制而成。塑胶部分也都标明了该塑胶的详细成份。

### 三、主要参数

- |         |         |        |         |         |          |
|---------|---------|--------|---------|---------|----------|
| 1. 钻夹头  | 2. 腰带扣  | 3. 通风口 | 4. 开关扳机 | 5. 调速旋钮 | 6. 开关锁定钮 |
| 7. 夹头钥匙 | 8. 开关拨杆 | 9. 手柄  |         |         |          |



为降低工具产生的电磁干扰对人身的影响, 同时防止机器附件割断隐藏着的电线或机器本身的电源线导致的触电风险, 必须通过绝缘握持面来握持工具。

皇冠产品型号	CT10125	CT10143	CT10143C	CT10127	CT10127C	CT10127-13	CT10127-13C	CT10179	CT10179C
额定功率 (W)	300	500	500	750	750	750	750	500	500
输出功率 (W)	130	280	280	392	392	392	392	275	275
额定电压 (V)	220-230	220-230	220-230	220-230	220-230	220-230	220-230	220-230	220-230
频率 (Hz)	50/60	50/60	50/60	50/60	50/60	50/60	50/60	50/60	50/60
对应电压下电流值 (A)	1.35	2.4	2.4	3.5	3.5	3.5	3.5	2.4	2.4
空载转速 (r/min)	0-3800	0-2800	0-2800	0-3000	0-3000	0-3000	0-3000	0-3200	0-3200
安全等级	回//	回//	回//	回//	回//	回//	回//	回//	回//
净重 (kg)	1	1.38	1.4	1.58	1.65	1.69	1.7	1.26	1.26
变速	是	是	是	是	是	是	是	是	是
夹头类型	钥匙夹头	钥匙夹头	自锁夹头	钥匙夹头	自锁夹头	钥匙夹头	自锁夹头	钥匙夹头	自锁夹头
夹持范围 (mm)	0.5-6.5	1.5-10	0.8-10	1.5-10	0.8-10	1.5-13	2-13	1-10	0.8-10
钻轴连接螺纹	3/8"-24UNF	3/8"-24UNF	3/8"-24UNF	3/8"-24UNF	3/8"-24UNF	1/2"-20UNF	1/2"-20UNF	3/8"-24UNF	3/8"-24UNF
	钢材 (mm)	10	10	10	10	13	13	10	10
钻孔	13	25	25	32	32	32	32	25	25

#### 四、功能操作说明



**警告! 维修电动工具或换装零、配件之前, 务必从插座上拔出插头。**

##### 安装侧手柄

操作之前, 请务必确认侧把手已安装牢固。请将侧手柄用螺丝固定在工具上如图1所示的所需位置。

##### 钻头安装与拆卸

1. 钥匙逆时针旋松卡盘, 将钻头装入夹头, 在3个孔中, 顺时针均匀旋紧卡盘; 拆卸钻头, 逆时针旋松卡盘, 取出钻头。(图2)
2. 握住套环并朝逆时针方向旋转套筒来打开夹头, 将钻头装入夹头, 握紧套环并顺时针方向旋转套筒来紧固夹头。拆卸钻头, 请握住套环并逆时针旋转套筒(图3)

##### 开关

1. 开启与闭合(图5)

将工具开关扳机缓慢按下, 则工具开始从慢到快运转, 完全按下后工具达到最高转速, 完全松开扳机则工具处于关闭状态。如果锁定开关, 则在扣起扳机的同时按下自锁钮。工具将连续运转; 再按动扳机完全松开, 即可使工具处于关闭状态。

2. 正反转开关(图6)

握持工具, 正反转拨杆朝“←”为正转; 朝“→”为反转

切记: 改变工具的旋转方向要等钻头完全停止后方可进行。

腰带扣, 使用皮带扣夹可将电钻挂在腰带上, 这样不仅可以空出双手, 工具也可唾手可得。

1. 使用规定电压, 线路电压不超过电钻铭牌上所规定电压正负5%方可使用。
2. 使用前的检查, 使用前空转一分钟, 检查传动是否灵活有异响, 火花是否正常。

##### 有效安全的操作方法

1. 钻孔 在钻削较大厚度或较硬材质的金属工件时, 需要使用合适的冷却剂, 否则会降低钻头的使用寿命。
2. 拧紧和拆卸螺钉 用螺丝刀和连杆(另购附件)可实现拆卸和拧紧螺钉。
3. 如何使用电源开关和功能转换开关, 按下开关便是开, 放开开关便是关, 从工作面上移动时, 电钻应关停。

##### 操作说明

1. 使用规定电压, 线路电压不超过电钻铭牌上所规定电压正负5%方可使用。
2. 使用前的检查: 使用前空转一分钟, 检查传动是否灵活、有异响, 火花是否正常
3. 如何使用电源开关和功能转换开关, 按下开关便是开, 放开开关便是关, 从工作面上移动时, 电钻应关停。
4. 为操作方便, 工具开关有一个锁定功能钮, 如图5所示右手按箭头方向搬动开关扳机到位后, 左手按下开关上面锁定钮, 然后松开右手开关扳机, 再放开锁定钮, 即开关锁定; 若要解锁, 搬动开关扳机即可。
5. 为满足不同使用情况需要, 可以调节开关调速旋钮(5)来调节输出转速的快慢。
6. 如何装拆钻夹头, 装钻夹头时, 将插入部分(即输出轴)擦干净, 并加少量油脂, 然后将输出轴螺纹端部对准钻夹头配合孔, 把电钻起动按顺时针方向缓慢转动, 左手握住钻夹头, 直至钻夹头与旋入输出轴的端面配合到位为止, 如钻头不到位, 会引起打孔晃动。最后用螺丝批把一枚M5\*20反螺纹螺钉旋入钻夹头内与输出轴拧紧。
7. 防止过载 使用钻头必须锋利, 钻孔时不宜用力过猛, 凡遇转速异常降低时, 应即减少用力, 电钻因故突然刹停或卡钻时, 必须立即切断电源。
8. 调换电刷 电刷磨损到一定程度时, 碳刷内小弹簧自动作用。切断电源, 电钻不转, 这时应调换电刷(二只电刷应同时调换)。
9. 在下列情况下不得使用 在使用过程中如发现绝缘损坏, 电源线或电缆护套破裂, 插头、插座裂或接触不良, 或严重火花等故障时, 应立即进行修理, 在未修复之前不得使用。如电钻过热也应停止使用。
10. 经常保持工具清洁 电钻的通风道必须保持清洁畅通, 并防止杂物入内。使用后应立即进行修整, 使电钻经常保持清洁和在最好的状态。
11. 用工具要爱惜, 所用工具要小心轻放, 避免受到冲击, 塑料件不能与汽油、酒精等接触, 以防龟裂。

##### 便利提示

1. 钻孔
  - a) 确保钻孔前先把物料夹稳, 如容易碎裂的薄片应用背板支撑以免钻孔时损坏工件。
  - b) 以直线向钻头施加压力, 用适当的压力使钻头进入, 但不要推力过猛, 会使马达失速或钻头偏离。
  - c) 如电钻失速, 可能是过载或使用不当, 切勿将扳机开关忽开忽关, 这会损坏电钻。
  - d) 为减少失速时引起物料损毁, 在孔将要钻穿时减慢速度及压力。
  - e) 当要把钻头从钻孔中拉出时, 应保持马达转动, 以防止钻头卡钻。



